

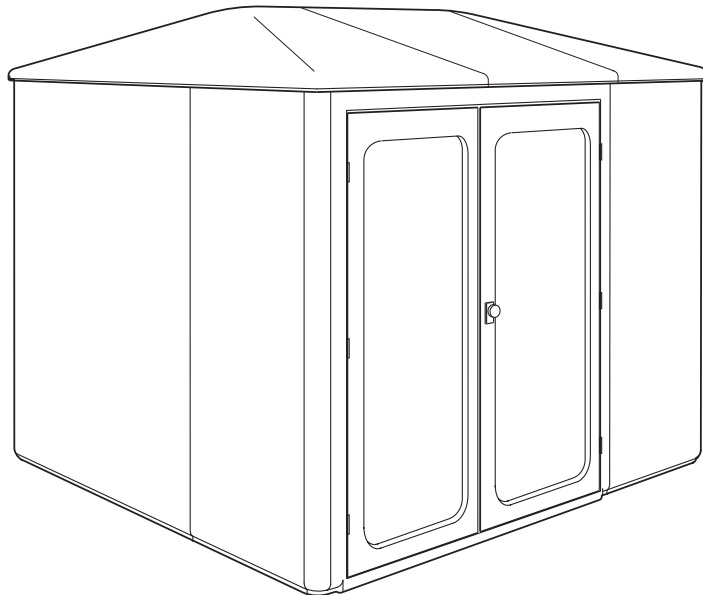

GARRISON HOUSINGS



ASSEMBLY INSTRUCTIONS

OCTOBER 2004

GLASDON UK LIMITED

Preston New Road • Blackpool • Lancashire • FY4 4UL

Tel: 01253 600400 • Fax: 01253 792558

e-mail: sales@glasdon-uk.co.uk • www.glasdon.com

Assembly Instructions

It is recommended that the assembly of housings of 2.5m high and above is carried out during calm weather conditions.

All assembly work must be carried out on a level concrete base. The minimum base size should be 250mm greater than the nominal internal size of the housing (see page 15).

Always aim to complete the assembly within a day (especially if a large housing is being constructed) even if a minimum number of flange bolts are initially installed. Suitable temporary bracing may be required to provide stability during the assembly or overnight stability if the shell is incomplete.

1 Panel Preparation

Prepare the panels as required.

Place the panel face up on padded trestles.

Apply 60mm x 10mm foam tape to one side flange of each panel as illustrated apply to both flanges where the panels become part of the corners ready to accept the corner posts (at stage 2).

Use a prodder to pierce the tape through the pre-drilled fixing holes.

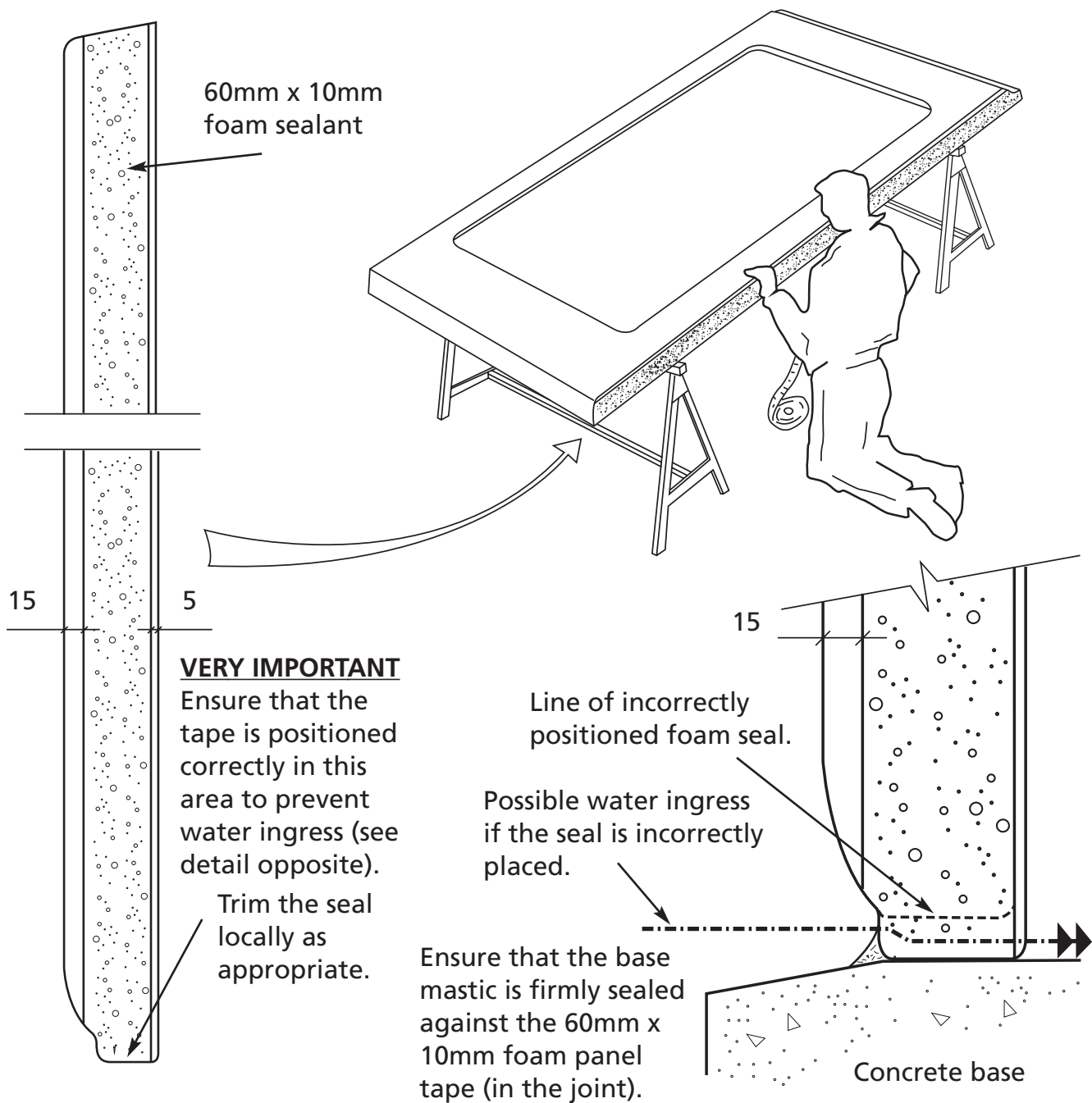

2 Corner Post Preparation

Prepare the corner post by loading the channels with the required number of M6 x 25mm bolts.

<u>Housing Height</u>	<u>No. of Bolts</u>
1.0m	6
1.5m	9
2.0m	11
2.5m	14
3.0m	16

Once the bolts have been inserted, reinstate the plastic cap to the top of the post and tap into position.

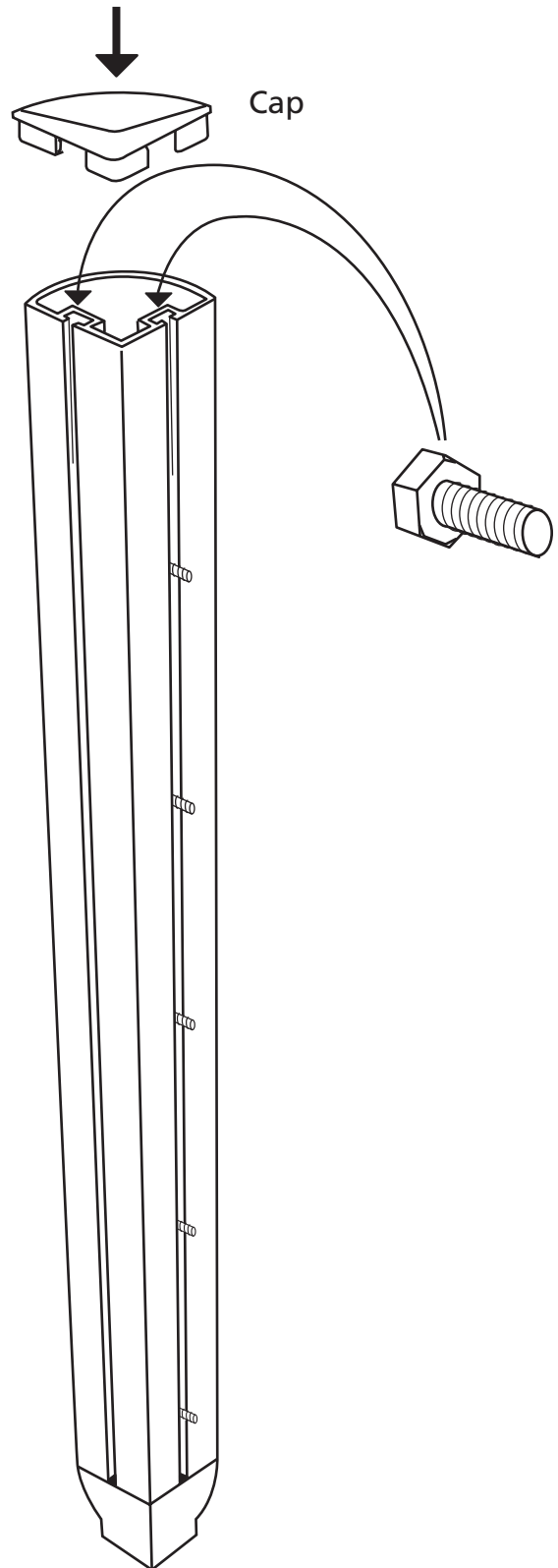

3 Corner Post Assembly

Place the panel face down on padded trestles. Loosely bolt the corner post to the bottom of the panel using M6 x 25mm bolts, nuts and washers, then work along the post locating the bolts. Ensure correct alignment at the base before finally tightening the fixings.

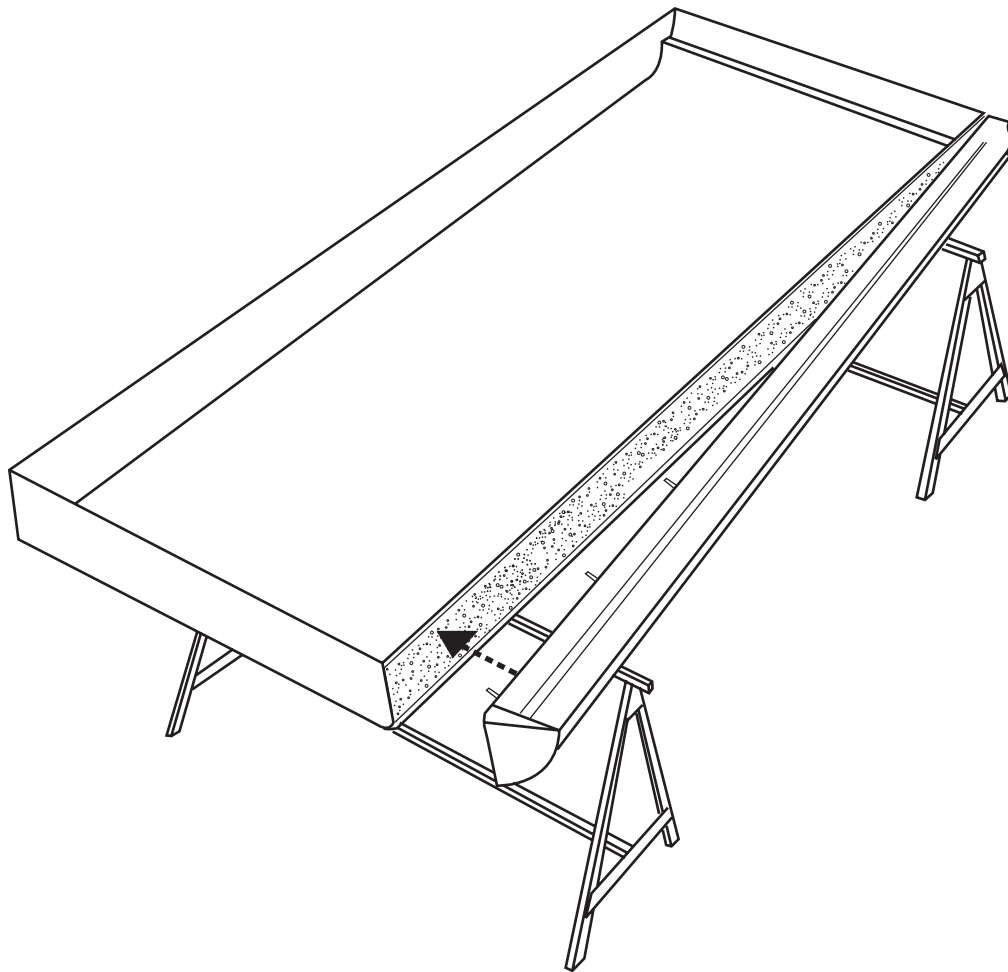

4 Corner Assembly

Repeat (3) with the second panel positioned, to form a self standing corner assembly.

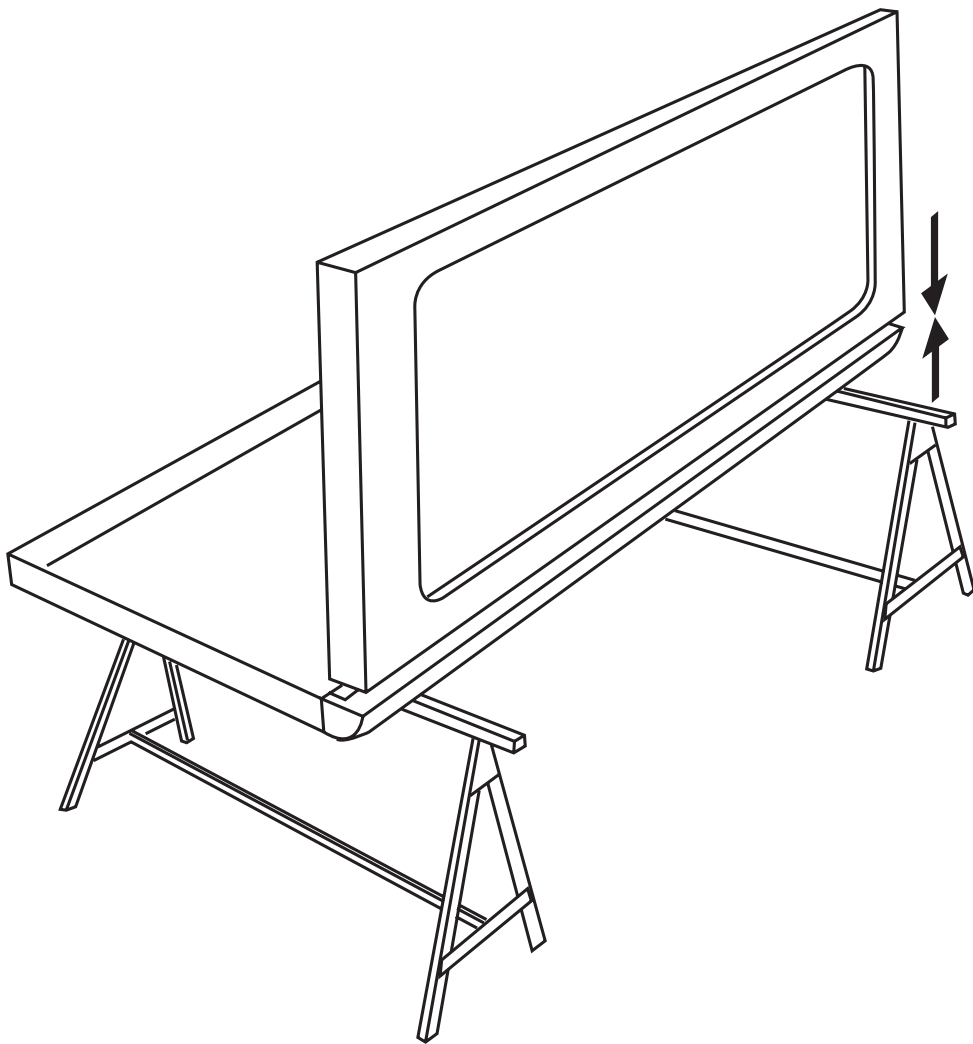

Alternative Corner Assembly Method

The housing corner may be assembled either in the horizontal position (as previously described) or in the vertical position depending on site conditions or available headroom.

It is recommended that assembly is carried out in the horizontal position whenever possible.

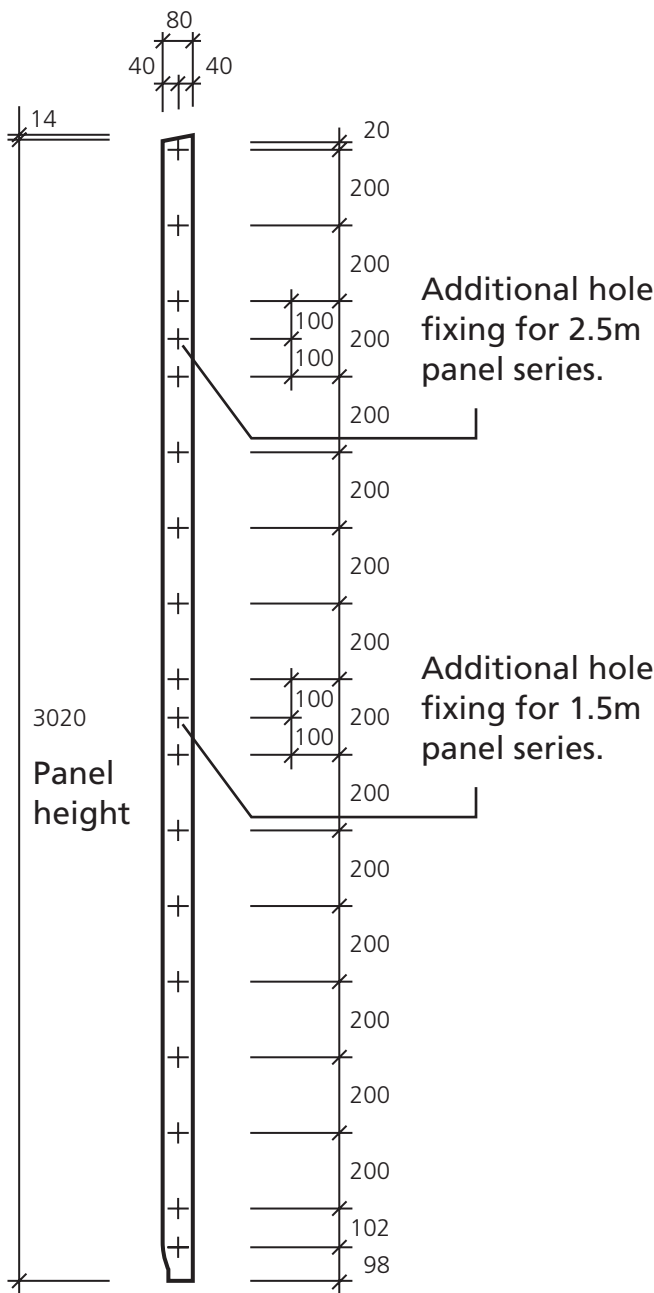

If it is decided to assemble the corner in the vertical position, a template may be produced to aid with assembly.

Alternatively, adhesive tape may be utilised to hold the bolts in position.

If none of the above provide a suitable method of assembly, the corner post may be fixed to the panel using self tapping screws.

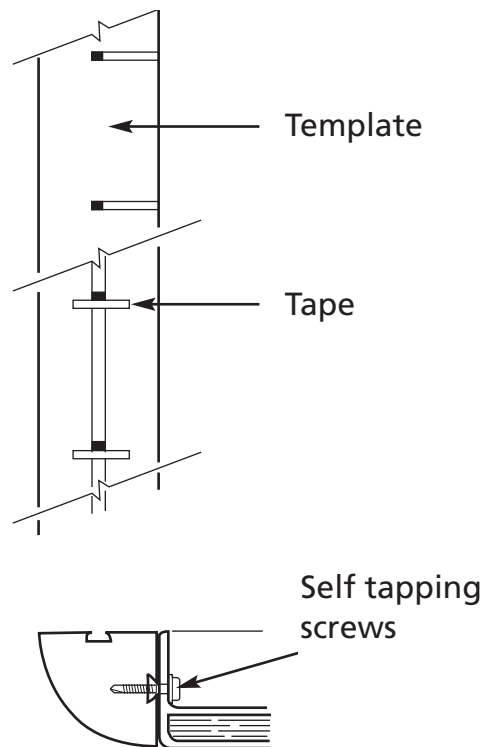

Optional Fixing

5 Wall Assembly

Stand a corner in the required position on the base plinth, then work around the perimeter of the housing, fixing panels into position using M6 x 25mm bolts, nuts and washers (washers to either side of the flanges). Abutting panel flanges should be temporarily clamped together, making sure that all fixing holes are in alignment.

Continue with one panel at a time, following the code which has been attached to each panel during pre-delivery assembly at our factory.

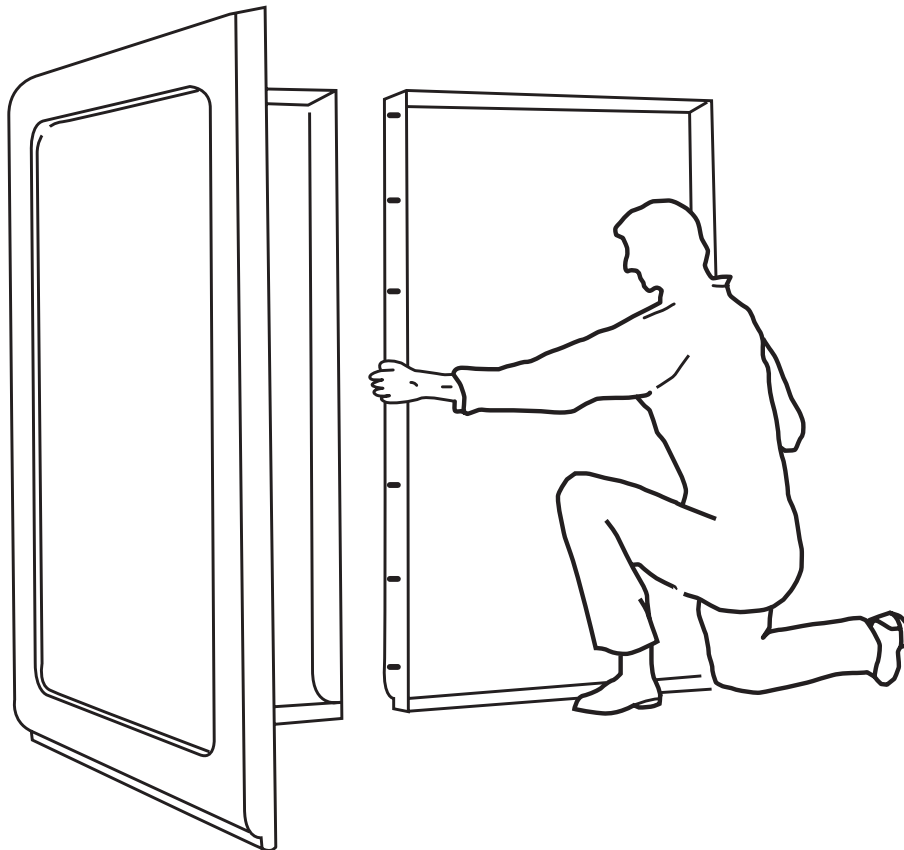

6 Modular or Jointed Roof Preparation

Place the roof section on trestles and apply 60mm x 10mm foam tape to one of the vertical flanges with the top edge of the foam positioned 10mm below the roof line.

Ensure that the foam tape is applied in a continuous length, and take special care to follow the profile of the roof. Jointing of the foam tape must be avoided to prevent potential roof leaks.

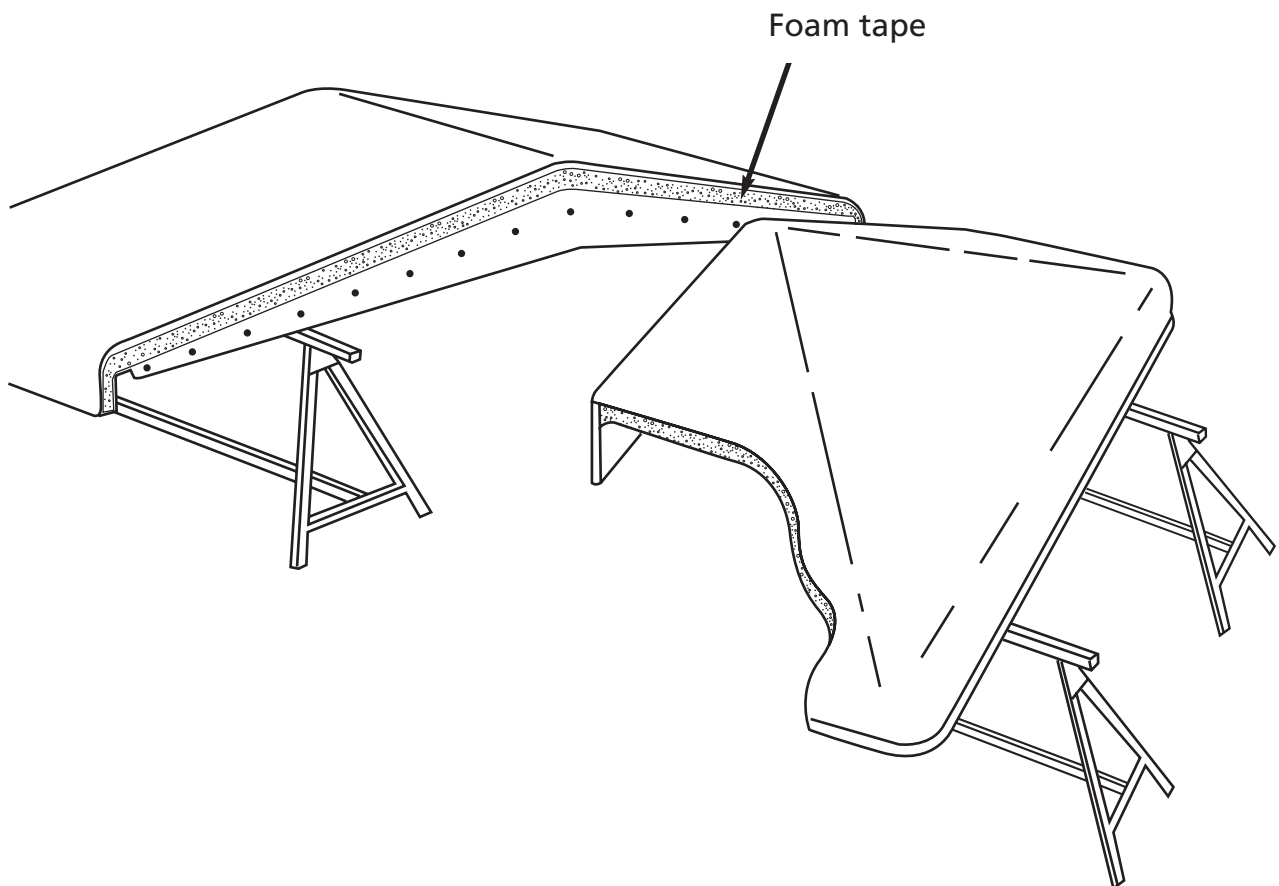

7 Roof Assembly

Apply 20mm x 20mm foam tape to the top flange of the wall panels.

Note: For ventilated eaves roofs this seal is not required.

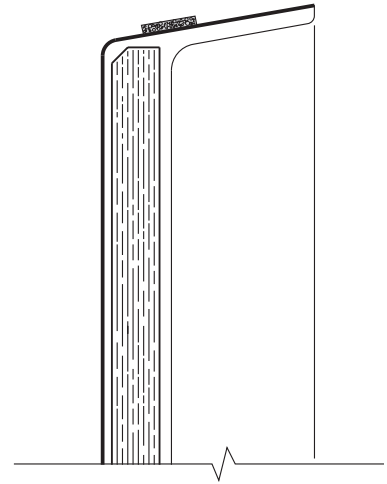

One Piece Roof

Depending upon the size and weight of the roof and the height of the housing, lift roof into position either manually as shown or with the use of a mechanical lifting aid.

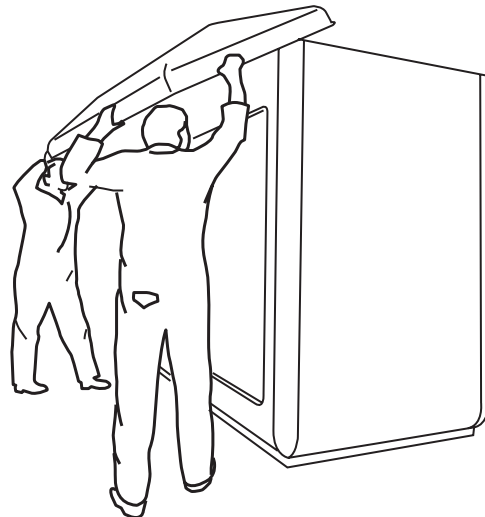

Modular Roof

Lift roof sections into position as required, and align, clamp and bolt together using M8 x 55mm setscrews, nuts and washers (washers to either side of flanges).

The use of a manually-operated crane and nylon slings is recommended: these are widely available from your local tool hire centre.

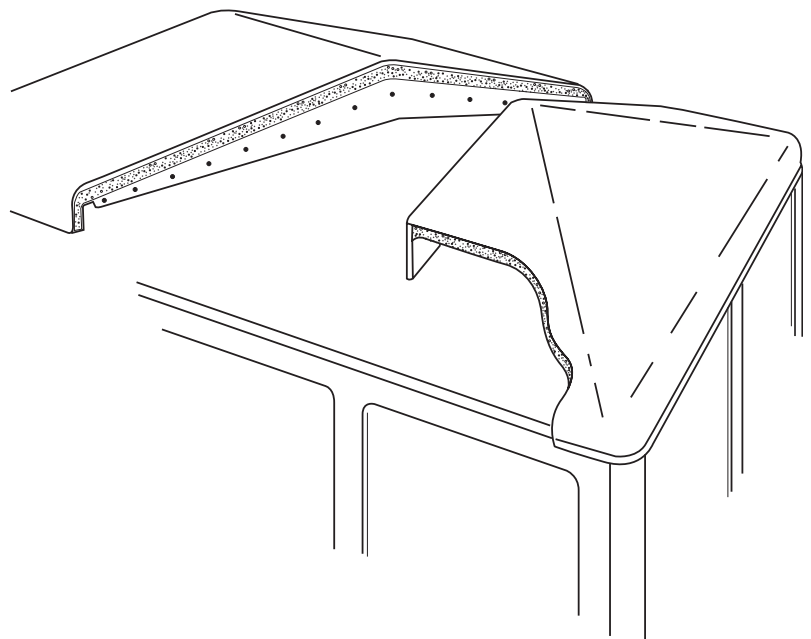

8 Standard Roof Fixing Detail

Check that the building is square, the panels are in line and the roof is located centrally with a 35mm nominal gap at the eaves.

Drill 4.8mm diameter pilot holes (through pre-drilled holes in the top of the wall panels) into the underside of the roof eaves to suit 32mm x 5.4mm self-tapping screws.

Install 5 no. screws for every 1m perimeter run.

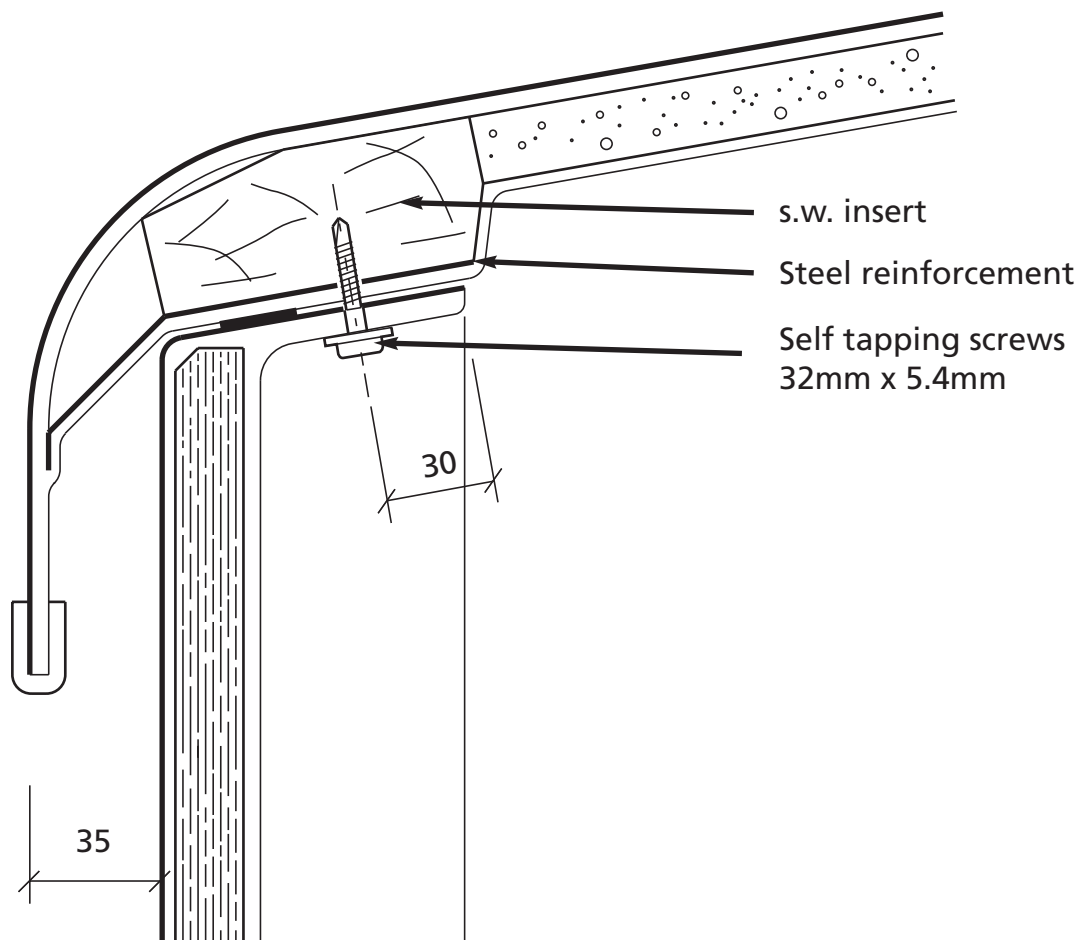

9 Roof Fixing (Ref K Eaves Ventilation Option)

Check that the building is square and the roof is located centrally with a 35mm nominal gap at the eaves.

Insert the ventilation grille between the raised roof brackets and the panel flange prior to drilling the holes to take M6 x 25mm holding down bolts (2 per spacer bracket).

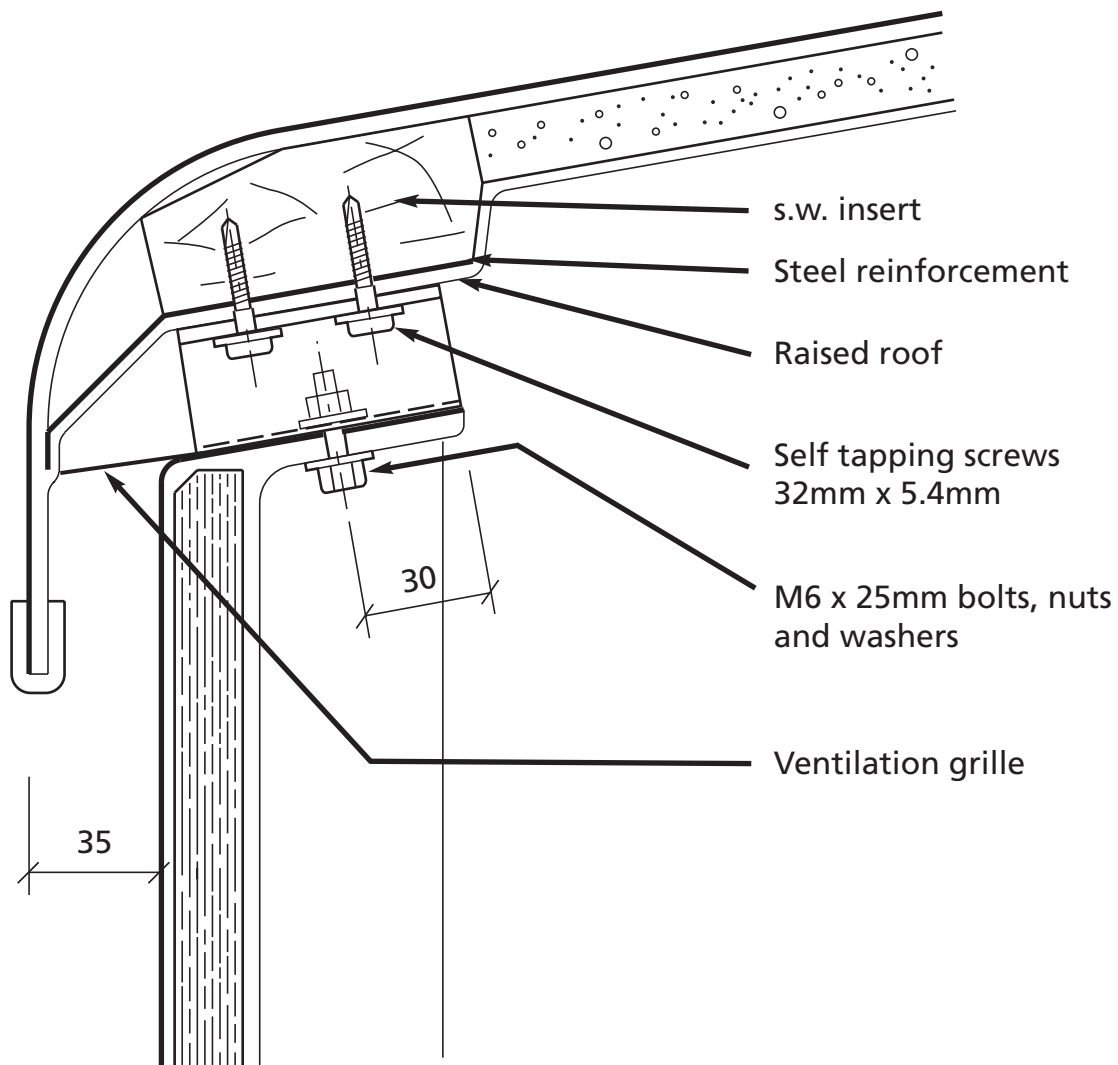

VENTILATED EAVES ROOF

One piece roof

Modular roof

BRACKET REQUIREMENT

- 1 no. bracket per 1 metre run, i.e. over the wall panel joint and one to each corner.
- 2 no. brackets per 1 metre run, i.e. two per wall panel adjacent to the joint.

10 Roof Finishing

Using a mallet, fit the 'knock-on-edging' trim onto the edge of the roof and align by eye to provide a pleasing finish. This can be helped by utilising a block of wood with the mallet.

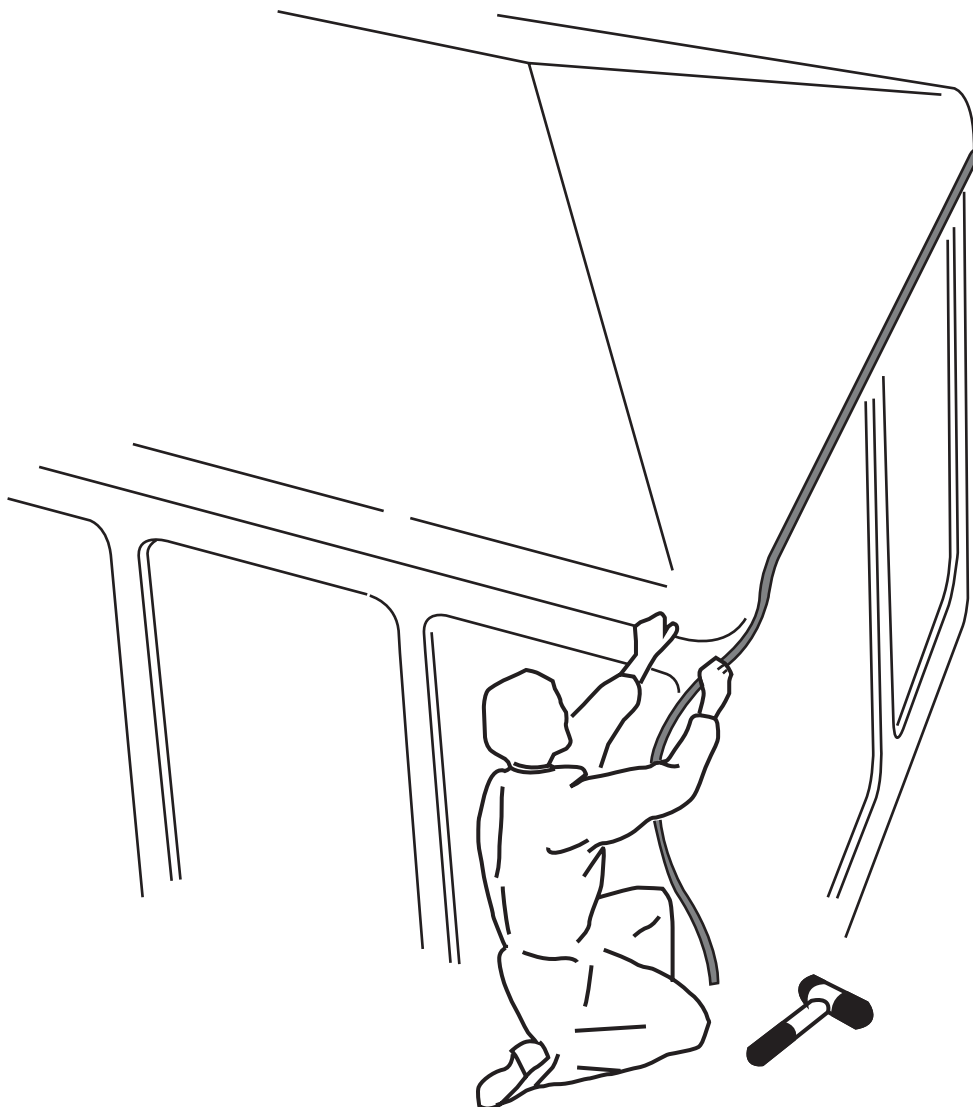

11 Base Fixing

Prior to base fixing, ensure that the panels are accurately aligned and the housing is completely square, i.e. the corners are at 90° and the diagonal dimensions are exactly the same.

Base fixing is accomplished using the M10 x 120mm electroplated expansion bolts supplied. 10mm holes should be drilled in the concrete base through the pre-drilled holes in the plinth, to a minimum depth of 100mm (2 no. bolts for each 1m panel).

Upon completion of base fixing (and assuming that the base is dry and primed if necessary), a bead of mastic seal (supplied) should be applied at the base of the wall panels to the perimeter of the Housing to provide a waterproof joint. The mastic seal should be tooled into position immediately after application.

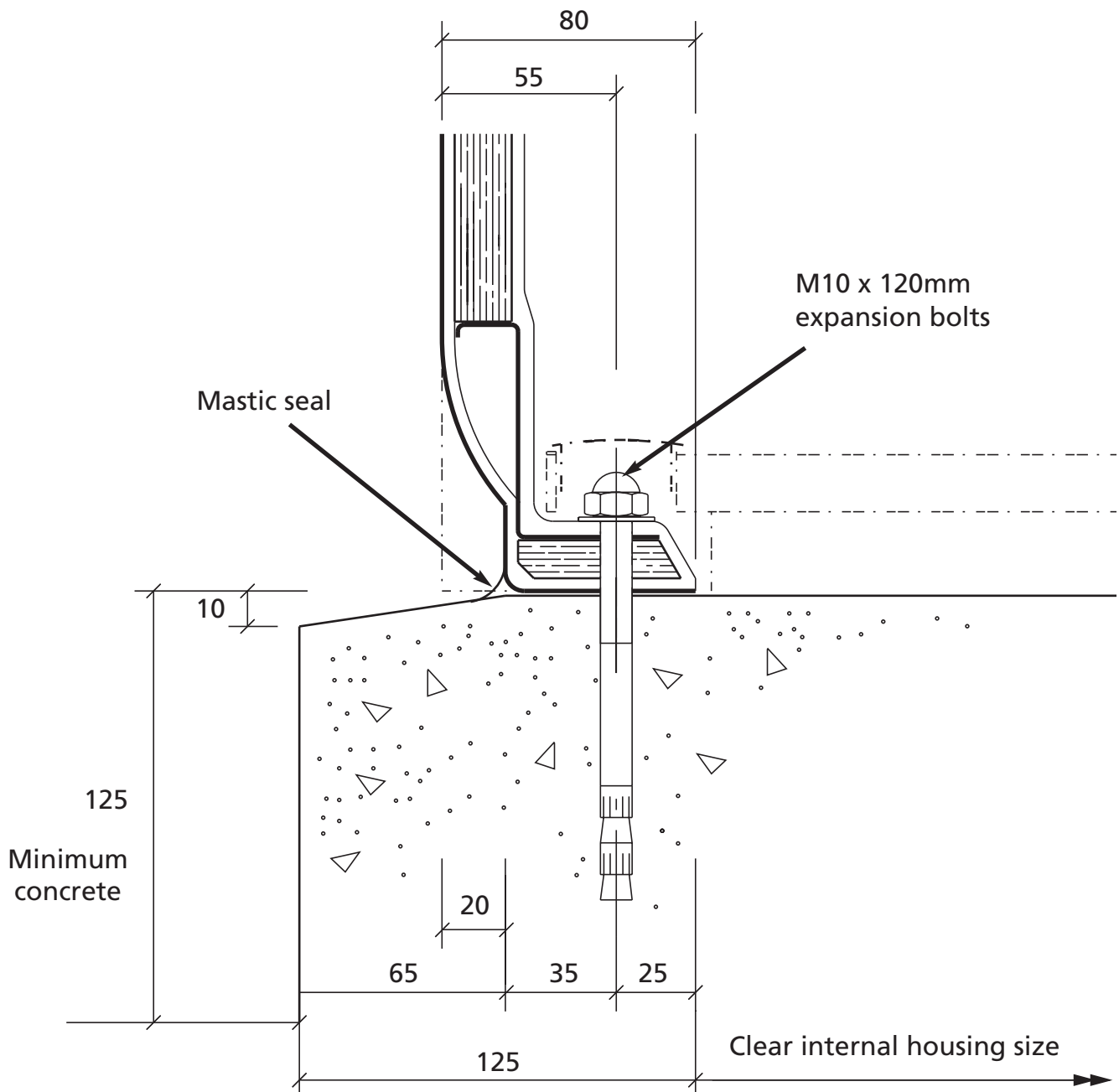

Base Fixing and Alignment Notes

- a) Try not to pull the building down and out of level.
Use solid packing pieces, especially adjacent to the door panels, as appropriate.
- b) Single door panels are not base fixed.
- c) When fixing the threshold to double door panels, note that the base fixing centre increases to 60mm (instead of 35mm).
- d) Any binding of doors or similar problems will be due to the panel being out of level and can be corrected by the use of packing materials.
- e) When applying a mastic seal to the perimeter base of the housing, ensure that the surfaces are clean and dry, and that the seal connects against the foam tape in the panel joints - see instruction (1) - otherwise leakage will occur.

Should you require any further assistance please contact us on
tel: 01253 600400, fax: 01253 792558 or email: sales@glasdon-uk.co.uk



In accordance with our policy of continuous development and improvement, we reserve the right to make changes in design and specification without notice.

Glasdon UK Limited products are manufactured under license worldwide and various components of the models are patented and design registered.



GLASDON UK LIMITED

Preston New Road • Blackpool • Lancashire • FY4 4UL

Tel: 01253 600400 • Fax: 01253 792558

e-mail: sales@glasdon-uk.co.uk • www.glasdon.com